

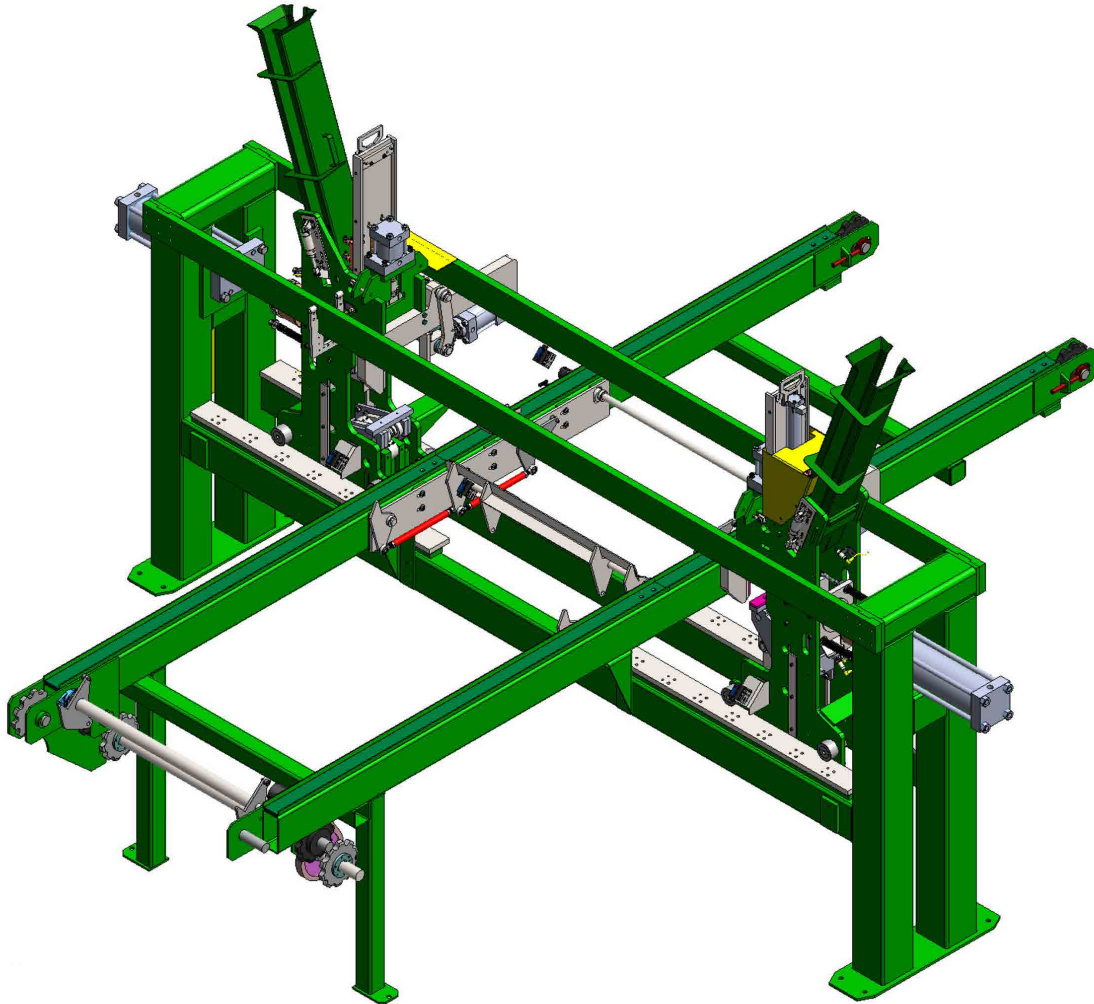

TIE PLATER



The Pendu Crosstie Plater is capable of applying plates to both ends of ties at a rate of ten ties per minute. The end plater automatically deals a tie, finds the ends (6' 6" – 9' range), squeezes any cracks out of ends (15,000 lbs each direction), issues plates (either 5" x 6" or 6" x 7"), and presses them on each end (70,000 lbs). The manually loaded magazine has a 36" capacity.

Tie Plater Specifications

Production	10 ties/minute
Material	6' 6" - 9'
Pressure	15,000 lbs. each direction
Plate Size	5" x 6" or 6" x 7" plate
Magazine Capacity	36"
Interchangeable Magazine	